

PENDANT PC

PENDANT COMPUTER

artech
art of technology

Medical Computer Solutions



Scan the QR code
for detailed information.



Artech Pendant Computer solution is lightweight, suitable for medical use, easily movable in any direction, and has a space-saving compact structure. It is designed to make the lives of healthcare personnel working in confined spaces, such as blood collection booths, easier.

KEY FEATURES

- **Easy Movement with Pendant Arm:** Provides flexibility and ease of use, allowing movement in any direction.
- **Multi-Axis Pendant Arm:** Offers ergonomic and flexible usage with the multi-axis pendant arm.
- **Built-in Barcode Reader:** Enables quick and accurate recording of patient information.
- **Thermal Label Printer Carrier:** Allows for practical and fast labeling with the label printer carrier feature.
- **Medical-Grade Body:** Hygienic and durable, suitable for medical use.

TECHNICAL SPECIFICATIONS

ORDER CODE

| | |
|------|---------------------------------|
| CPU | : N2930 |
| PSU | : AC110/220, DC12/24, PoE |
| RAM | : R4, R8 |
| HDD | : HDD 320GB, SSD 32GB, SSD 64GB |
| Wifi | : Optional |

SYSTEM

| | |
|----------------|-----------------------------------|
| CPU | : Intel® Celeron® N2930 |
| Cache | : 2MB |
| Memory | : 2 x DDR3 SoDIMM maks. 4GB / 8GB |
| Video RAM | : Max. 128 MB Shared Memory |
| Chipset | : N.A |
| Watchdog Timer | : 255 Level Reset |
| System Fan | : Fanless |

INPUT/OUTPUT

| | |
|----------------|-------------------------------------|
| Serial Port | : 3 x RS-232 ports |
| Parallel Port | : N.A. |
| USB Port | : 4 x USB 2.0 |
| KB / MS | : 1 x PS2 K/B and Mouse |
| LAN | : 1 x LAN Realtek Gigabit Ethernet |
| Wireless LAN | : 802.11 b / g (Optional) |
| Audio | : Line in & out (AC'97 Codec Audio) |
| Expansion Slot | : MiniPCIe |

MECHANICAL PROPERTIES

| | |
|----|------------------|
| 1. | : Pendant Arm |
| 2. | : Barcode Reader |
| 3. | : Printer Stand |

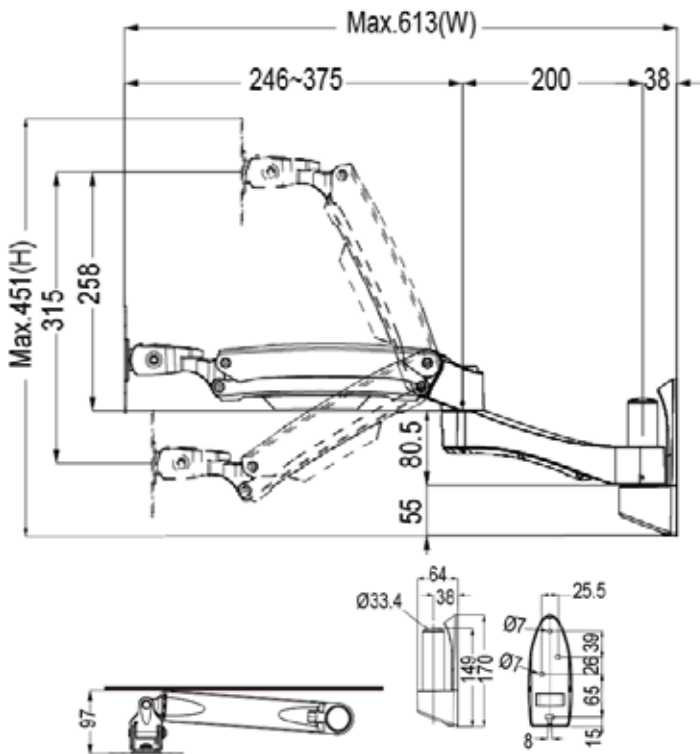

DATA STORAGE

| | |
|------------|----------------|
| HDD / Type | : 2.5" HDD/SSD |
|------------|----------------|

FEED

| | |
|-------|----------|
| Input | : 220VAC |
|-------|----------|

LCD SCREEN

| | |
|-----------------|--------------------------|
| Type and Size | : 10.1" / 16:9 |
| Max. Resolution | : 10.1" 1280 x 800 |
| Pixel Pitch | : 0.297mm x 0.297mm |
| Max Color | : 16.7 M |
| Brightness | : 250cd |
| Contrast Ratio | : 700/1 |
| Back Light MTBF | : 50,000 Hours |
| Touch Screen | : 10.1" Capacitive Touch |

EXTRA VIDEO OUTPUT

| | |
|-----------------|--------------------|
| Type | : HDMI |
| Max. Resolution | : 1920x1080 @ 60Hz |

MECHANICAL & ENVIRONMENTAL FEATURES

| | |
|------------------|-------------------------------------|
| Working Temp. | : 0 ~ 60°C |
| Storage Humidity | : 5 ~ 95% (Non-Condensing) |
| Case | : Heavy-Duty Metal Case |
| Front Frame | : Glass |
| Weight | : Variable According to Screen Size |
| Dimensions | : Variable According to Screen Size |
| Mounting | : Pendant |

